

## TECHNICAL DATA SHEET

1.	Manufacturer		<b>DEUTRUCK</b>
2.	Type	model designation	DFG 5G
3.	Capacity	Q	kg 5.000
4.	Load centre	c	mm 600
5.	Type of drive	electr. , diesel, LPG	diesel
6.	Operator type	stand on / driver seated	driver seated
7.	Tyre	C = cushion / P = pneumatic / SE = super elastic	P
8.	Wheels (x=driven)	number front/rear	4 x 2
9.	Lift	h3 standard lift height	mm 3.000
10.		h2 standard free lift	mm 260
11.		h5 special free lift	mm
12.	Forks	length x width x thickness	mm 1.150 x 125 x 50
13.	Fork carriage	FEM 4A	
14.	Fork carriage width	b3	mm 1.950
15.	Tilting	forward / backward	(°) 15 / 15
16.	Dimensions	l1 length with forks	mm 4.865
17.		l2 length without forks	mm 3.665
18.		b1 overall width	mm 2.105
19.		h1 mast standard lowered	mm 2.685
20.		h4 mast standard extended	mm 4.534
21.		h6 height of overhead guard	mm 2.575
22.		h7 seat height	mm
23.	Turning radius	Wa or WA'	mm 3.550
24.	Load distance	x = centre of drive axle to fork	mm 735
25.	Aisle width for 90° stacking	1.000 x 1.200 / 800 x 1.200 pallets	mm 6.305
26.	Stability	DIN 15138 (FEM)	Yes
27.	Speeds	travel unladen	km/h 25
28.		lift laden	m / s 0,45 / 0,52
29.		lower laden	m / s 0,50 / 0,43
30.	Drawbar pull	at the hook laden	N 77.000
31.	Gradeability	laden	% 39
32.	Weight of truck		kg 8.700
33.	Axle loading	unladen front / rear	kg 4.150 / 4.550
34.		laden front / rear	kg 12.200 / 1.500
35.	Wheels (x=driven)	number front / rear	4 x 2
36.	Tyres	dimensions front	“ or mm 445 / 65 – 22,5
37.		dimensions rear	“ or mm 12.5 / 80 - 18
38.	Wheelbase	y	mm 2.150
39.	Tread front / rear	b 10 / b 11	mm 1.660 / 1.760
40.	Ground clearance	m1 under mast laden	mm 385
41.		m2 centre of wheelbase	mm 370
42.	Brakes	service brake	hydr.
43.		parking brake	hand
44.	Battery	type	starter
45.		Volt / Ah cap.	24 /90
46.	Engine	manufacturer / type	DEUTZ TCD 3,5 L4
47.		continuous output ISO 1585	kW 55,4
48.		rated speed ISO 1585	cycl.p.m. 2.300
49.		number of cylinders / capacity	cm³ 4 / 3.620
50.		consumption	l / h
51.	Tow coupling		
52.	Transmission		powershift
53.	Gear change	forward / backward	
54.	Sound level	in drivers ear	db(A) 79
55.	Operating pressure		bar 160

according to VDI 2198 - standard version - subject to modification without pre-advice

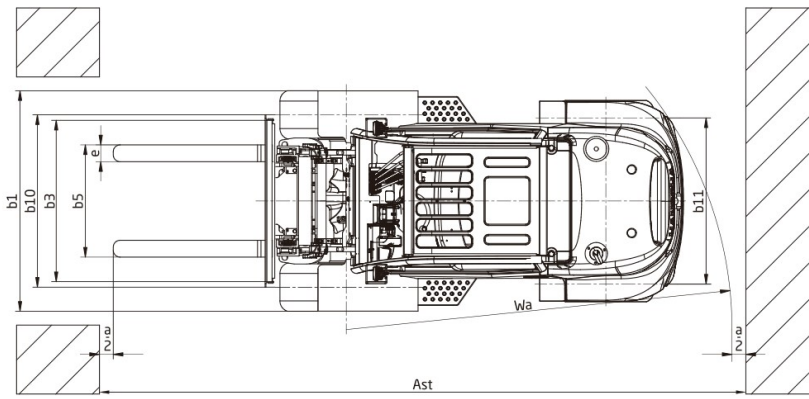
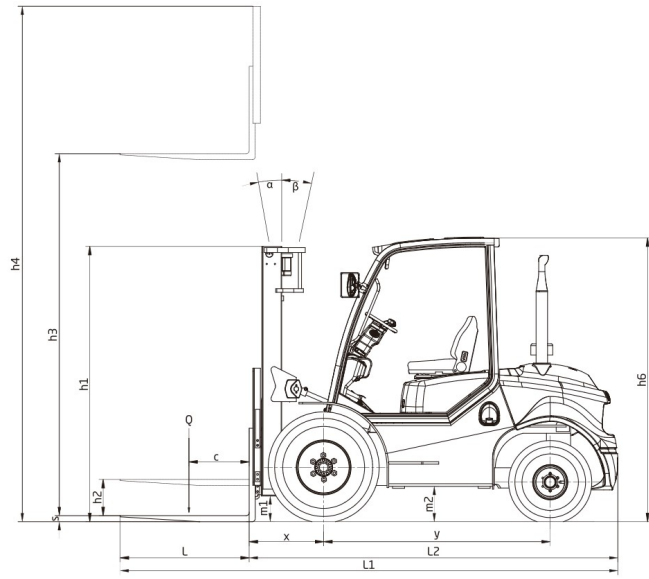

### LOAD CHART

