

# TECHNICAL DATA SHEET

1.	Manufacturer		<b>DEUTRUCK</b>
2.	Type	model designation	DFG 8
3.	Capacity	Q	kg 8.000
4.	Load centre	c	mm 600
5.	Type of drive	electr. , diesel, LPG	diesel
6.	Operator type	stand on / driver seated	Driver seated
7.	Tyre	C = cushion / P = pneumatic / SE = super elastic	L
8.	Wheels (x=driven)	number front/rear	4x / 2
9.	Lift	h3 standard lift height	mm 3.000
10.		h2 standard free lift	mm 200
11.		h5 special free lift	mm
12.	Forks	length x width x thickness	mm 1.500 x 160 x 75
13.	Fork carriage	FEM 4A	
14.	Fork carriage width	b3	mm 2.000
15.	Tilting	forward / backward	(°) 6 / 12
16.	Dimensions	l1 length with forks	mm 5.504
17.		l2 length without forks	mm 4.004
18.		b1 overall width	mm 2.165
19.		h1 mast standard lowered	mm 2.700
20.		h4 mast standard extended	mm 4.210
21.		h6 height of overhead guard	mm 2.580
22.		h7 seat height	mm 1.505
23.	Turning radius	Wa or WA'	mm 3.730
24.	Load distance	x = centre of drive axle to fork	mm 714
25.	Aisle width for 90° stacking	1.000 x 1.200 / 800 x 1.200 pallets	mm 5.644 / 5.844
26.	Stability	DIN 15138 (FEM)	Yes
27.	Speeds	travel laden/unladen	km/h 28/32
28.		lift laden/unladen	mm / s 390/-
29.		lower laden/unladen	mm / s 455/-
30.	Drawbar pull	at the hook laden / unlade	N 65.000 / 45.000
31.	Grade ability	laden	% 20
32.	Weight of truck		kg 12.000
33.	Axle loading	unlade front / rear	kg 4.820 / 7.180
34.		laden front / rear	kg 17.980 / 2.020
35.	Wheels (x=driven)	number front / rear	4x / 2
36.	Tyres	dimensions front	“ or mm 10.00-20-14 PR
37.		dimensions rear	“ or mm 10.00-20-14 PR
38.	Wheelbase	y	mm 2.600
39.	Tread front / rear	b 10 / b 11	mm 1.628/1.700
40.	Ground clearance	m1 under mast laden	mm 250
41.		m2 centre of wheelbase	mm 339
42.	Brakes	service brake	hydraulic
43.		parking brake	Spring arrested
44.	Battery	type	Starter
45.		Volt / Ah cap.	2x12V/90
46.	Engine	manufacturer / type	DEUTZ TCD 3.6 L4
47.		continuous output ISO 1585	kW 85
48.		rated speed ISO 1585	cycl.p.m. 2.200
49.		number of cylinders / capacity	cm <sup>3</sup> 4
50.		consumption	l / h 8,1
51.		emission standard/ catalyser oxy	EUR V
52.	Tow coupling		
53.	Transmission	torque converter	
54.	Gear change	forward / backward	
55.	Sound level	in drivers ear	db(A) 82
56.	Operating pressure		bar 195

according to VDI 2198 - standard version - subject to modification without pre-advice

Version : 07/2021

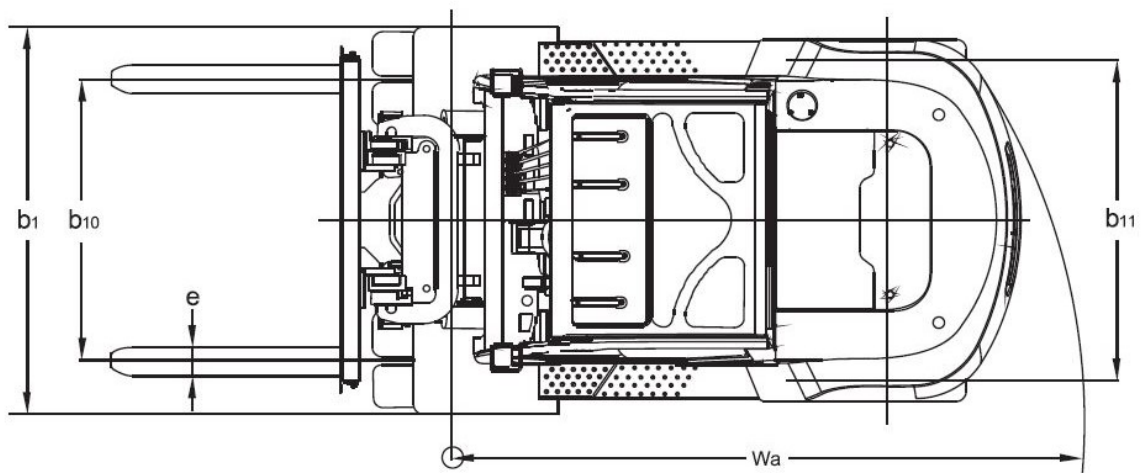
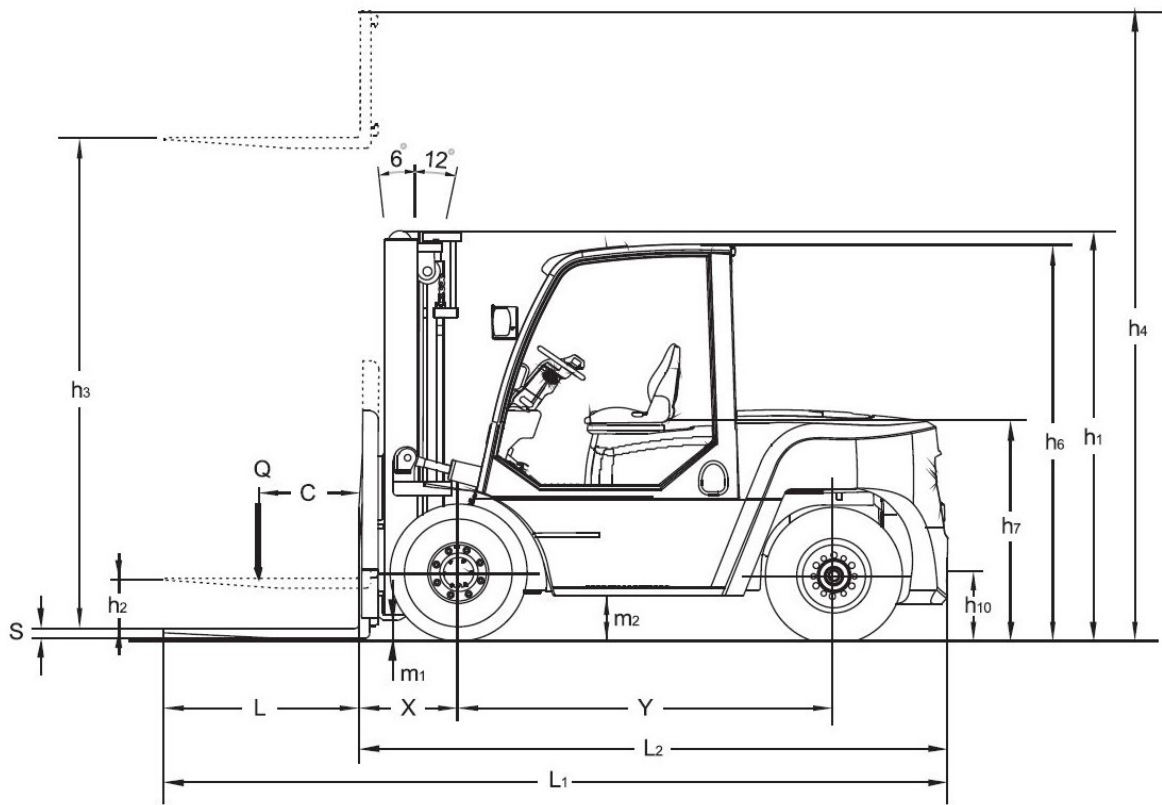

### LOAD CHART

